

Plastic Modular Belt

Serie **uni L-SNB** Type **Rib 36%**

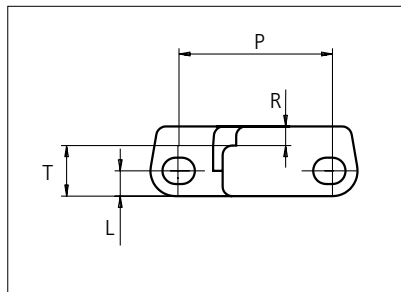

Straight running belt
 Nominal pitch: 50.0 mm (1.97 in)
 Surface type: Rib Top
 Surface opening: 36%
 Backflex radius: 140.0 mm (5.50 in)
 Pin diameter: \varnothing 8.0 mm (0.31 in)

Belt material & color	POM-LF BR	PP G	PP-HW LB	mm	in	T	mm	in
Pin and lock material & color	PP W	PP G	PP-HW LB	P (Nominal)	50.0	1.97	L	8.0

Non standard material and color: See uni Material and Color Overview.

Alternative pin and lock materials: Pin: PE **W** SS304

Belt width		Permissible tensile force (Belt/pin material)				Belt weight (Belt/pin material)				*Min. No. drive sprocket per shaft	Number of wear strips (Min. No.)	
		PP/PP		POM/LF-PP		PP/PP		POM/LF-PP			**Carry (pcs)	**Return (pcs)
mm	in	N	lbf	N	lbf	kg/m	lb/ft	kg/m	lb/ft			
153	6.0	4559	1025	8415	1892	1.5	1.01	2.3	1.52	2	2	2
229	9.0	6826	1535	12599	2832	2.2	1.51	3.4	2.28	2	2	2
305	12.0	9093	2044	16783	3773	3.0	2.01	4.5	3.04	3	3	2
381	15.0	11360	2554	20967	4713	3.7	2.51	5.6	3.79	3	3	2
457	18.0	13627	3063	25151	5654	4.5	3.01	6.8	4.55	4	4	2
533	21.0	15894	3573	29335	6595	5.2	3.51	7.9	5.31	4	4	2
609	24.0	18161	4083	33519	7535	6.0	4.01	9.0	6.06	5	5	3
686	27.0	20428	4592	37703	8476	6.7	4.51	10.1	6.82	5	5	3
762	30.0	22695	5102	41887	9416	7.5	5.02	11.3	7.57	6	6	3
838	33.0	24962	5611	46071	10357	8.2	5.52	12.4	8.33	6	6	3
914	36.0	27229	6121	50255	11297	9.0	6.02	13.5	9.09	7	7	4
990	39.0	29496	6631	54439	12238	9.7	6.52	14.6	9.84	7	7	4

Additional standard belt widths are available in steps of 76.1 mm (3.00 in.)

1980	78.0	59004	13264	108900	24481	19.4	13.04	29.3	19.69	14	14	7
------	------	-------	-------	--------	-------	------	-------	------	-------	----	----	---

Additional standard belt widths are available in steps of 76.1 mm (3.00 in.)

2969	116.9	88476	19889	163295	36709	29.1	19.55	43.9	29.53	20	20	10
------	-------	-------	-------	--------	-------	------	-------	------	-------	----	----	----

General belt tolerance is +0/-0.4% at 23°C/73°F and 50% RH. For exact belt width contact Customer Service. Non standard belt width on request.

*Max. Load per Drive Sprocket. Belt material: PP-HW with snub roller 2000 N (450 lbf), PP-HW without snub roller 1250 N (281 lbf)

**Max. Spacing between wear strips, Carry: 152 mm (6 in.) ; Return: 304 mm (12 in.)

***Load capacity per row of reinforcement links in the belt: 2500 N (562 lbf)

***Example: Belt with 8 rows of reinforcement links, permissible load is 8 x 2500 N (562 lbf) = 20000 N (4496 lbf)

= Single Link

Any questions? Please contact us.

Morskate Aandrijvingen BV
 Oosterveldsingel 47A
 7558 PJ Hengelo (Ov)
 The Netherlands

NL
 T +31 (0)74 - 760 11 11
 info@morskateaanrijvingen.nl
 www.morskateaanrijvingen.nl

DE
 T +49 692 - 222 34 95
 info@morskateantriebstechnik.de
 www.morskateantriebstechnik.de

EN
 T +31 (0)74 - 760 11 11
 info@morskatedrivetechnology.com
 www.morskatedrivetechnology.com

STANDARD

STRAIGHT RUNNING

PITCH 50.0 MM/1.97 IN

Accessories

Reinforcement Link

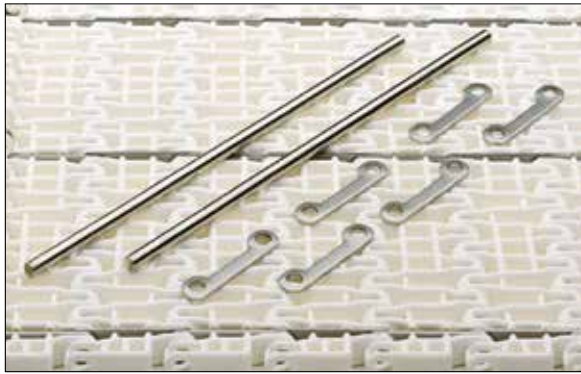

The use of uni-chains belts with the SS reinforcement /pitch control links in blanchers, cookers and other high temperature applications will reduce belt elongation due to temperature by more than 90%. This will simplify the belt take-up system and reduce maintenance. uni-chains recommends three reinforcement links per K1200 module.
Note: Reinforcement links require the use of SS pins.

Type	Material & color	N/row	Lbf/row
Steel Link	SS316	2500	562

Non Standard material and color: See uni Material and Color Overview.

Accessories

Finger Plates

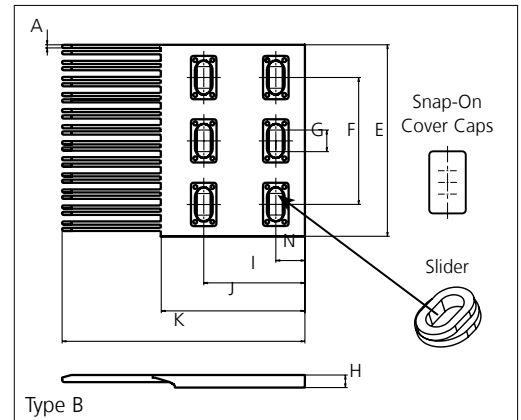
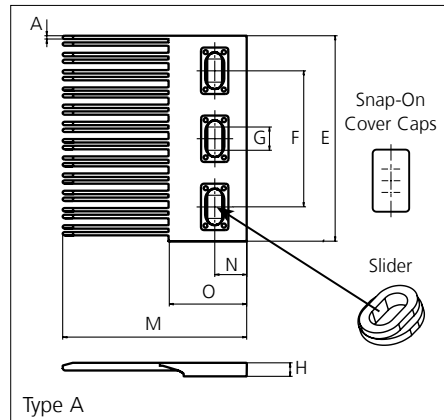
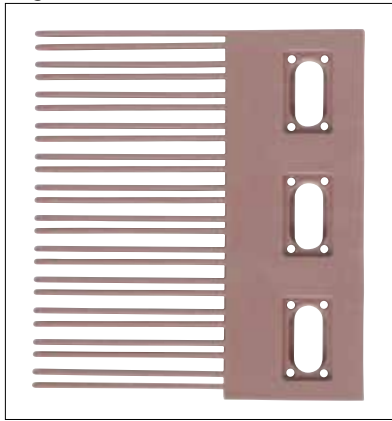

Type	Material & color	A		E		F		G					
		mm	in	mm	in	mm	in	mm	in				
Single Sided 150x149	POM-LF BR POM-DI G	2.5	0.10	152.1	5.99	100.3	3.95	12.0	0.47				
Single Sided 120x149													
H		I		J		K		M		N		O	
mm	in	mm	in	mm	in	mm	in	mm	in	mm	in	mm	in
10.0	0.39	80.0	3.15	114.0	4.49	192.0	7.56	135.0	5.31	23.0	0.91	57.0	6.18

All uni-chains belt systems are available in a raised rib version that can be supplied with matching finger plates, also called combs.

The finger plates are supplied with cover caps which can be attached when the finger plate has been installed. The cover caps can be removed by using a screwdriver that can be inserted between the cover and finger plate. In order to adjust to belt width variations caused by temperature fluctuations, a slider facilitates the sideways movement of the finger plates.

Non Standard material and color: See uni Material and Color Overview.

Any questions? Please contact us.

Morskate Aandrijvingen BV

Oosterveldsingel 47A
7558 PJ Hengelo (Ov)
The Netherlands

NL

T +31 (0)74 - 760 11 11
info@morskateaandrijvingen.nl
www.morskateaandrijvingen.nl

DE

T +49 692 - 222 34 95
info@morskateantriebstechnik.de
www.morskateantriebstechnik.de

EN

T +31 (0)74 - 760 11 11
info@morskatedrivetechnology.com
www.morskatedrivetechnology.com

Sprocket

No of teeth	Bore size													Overall diameter		Pitch-diameter		Hub-diameter		A-dimension		B-dimension		Single row/One way	Double row/Two way	Material	
	Pilot bore		0.75	0.78	0.98	1.00	1.18	1.25	1.50	1.57	2.36	2.50	3.54													mm	in
	mm	in												PA6	PA6 LG												
Z06	x						●	●	■	●				92.5	3.64	100.0	3.94	70.0	2.76	35.3	1.39	58.0	2.28	x		x	
Z08	x						●	●	■	●				128.7	5.07	130.7	5.15	70.0	2.76	52.4	2.06	73.3	2.89	x		x	
Z10	x						●	●	■	●				159.8	6.29	161.8	6.37	70.0	2.76	68.9	2.71	88.9	3.50	x		x	
Z10														159.8	6.29	161.8	6.37	120.0	4.72	68.9	2.71	88.9	3.50	x			x
Z12	x						●		■	●				192.5	7.58	193.2	7.61	70.0	2.76	85.3	3.36	104.6	4.12	x		x	
Z12														192.5	7.58	193.2	7.61	120.0	4.72	85.3	3.36	104.6	4.12	x			x
Z16	x						●	■	●					257.3	10.13	256.3	10.09	120.0	4.72	117.7	4.63	126.1	4.96	x			x

■ Molded sprocket

● Molded sprocket

■ Machined sprocket

● Machined sprocket

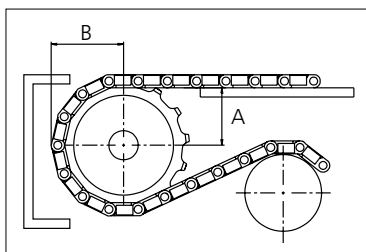

Other sprocket sizes are available upon request.
 Two-part sprocket are available upon request.
 Round bores are always delivered with keyway.
 Other bore sizes are available upon request.
 uni Retainer Rings: See uni Retainer Ring data sheet
 Width of tooth = 7.0 mm (0.28 in)
 Width of sprocket = 42.3 mm (1.67 in)

Max load per sprocket shown does not take bore size into account.
 Please also ensure that sufficient size shaft is chosen for corresponding load.

For correct sprocket position: See uni Assembly Instructions for uni L-SNB.
 For more detailed sprocket information, contact Customer Service.

Non standard material and color: See uni Material and Color Overview.

Any questions? Please contact us.

Morskate Aandrijvingen BV
 Oosterveldsingel 47A
 7558 PJ Hengelo (Ov)
 The Netherlands

NL
 T +31 (0)74 - 760 11 11
 info@morskateaandrijvingen.nl
 www.morskateaandrijvingen.nl

DE
 T +49 692 - 222 34 95
 info@morskateantriebstechnik.de
 www.morskateantriebstechnik.de

EN
 T +31 (0)74 - 760 11 11
 info@morskatedrivetechnology.com
 www.morskatedrivetechnology.com